

80JB100K / 71110 直流齿轮减速电机 80JB100K/71110 PM DC GEAR MOTOR

80mm 100K 齿轮减速
80mm100k PLANETARY GEAR

● 外形和安装尺寸 Dimensions

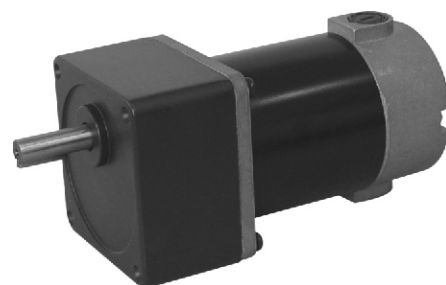
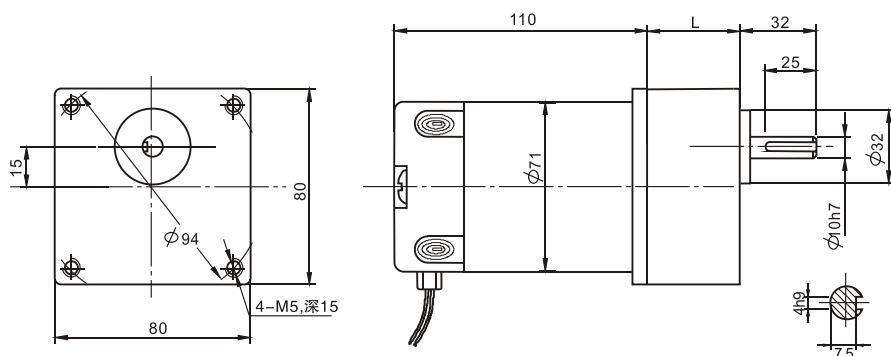

● 电动机主要技术参数 Motor Technical Data

电机型号 TYPE	额定电压 Rated voltage VDC	空载转速 No-load speed r/min	空载电流 No-load current A	额定转速 Rated speed r/min	额定转矩 Rated torque kg.cm	输出功率 Output power W	额定电流 Rated current A	堵转转矩 Stall torque kg.cm	堵转电流 Stall current A
71110-2420	24	2000	0.40	1600	2.0	33	2.4	10	9.5
71110-2430	24	3000	0.50	2400	2.4	59	3.5	12	14

可以制造12V产品，转速、转矩指标与24V产品基本一致。

We can produce products of 12V. The index of rotating speed and torque is consistent with 24V.

● 齿轮减速电机主要技术参数 Gear motor Technical Data

80JB100K/71110-2420(71ZY110-2420)

减速比 Reduction ratio	3	5	7.5	12.5	15	25	30	50	75	100	120	150
减速级数 Number of gear trains	2	2	2	2	2	3	3	4	4	4	4	4
减速器长度(L) Length(L) mm	35	35	35	35	35	45	45	45	45	45	45	45
空载转速 No-load speed r/min	667	400	267	160	133	80	67	40	27	20	17	13
额定转速 Rated speed r/min	533	320	213	128	106	64	53	32	21	16	14	11
额定转矩 Rated torque kg.cm	5	8	12	20	24	36	44	66	98	100	100	100
最大瞬间允许负载 Max. permissible load in a short time kg.cm	25	60	60	60	60	100	100	200	200	200	200	200

80JB100K/71110-2430(71ZY110-2430)

减速比 Reduction ratio	3	5	7.5	12.5	15	25	30	50	75
减速级数 Number of gear trains	2	2	2	2	2	3	3	4	4
减速器长度(L) Length(L) mm	35	35	35	35	35	45	45	45	45
空载转速 No-load speed r/min	1000	600	400	240	200	120	100	60	40
额定转速 Rated speed r/min	800	480	320	192	160	96	81	48	34
额定转矩 Rated torque kg.cm	6	17	14	24	29	44	50	79	100
最大瞬间允许负载 Max. permissible load in a short time kg.cm	25	60	60	60	60	100	100	200	200